

**WIRING KEY**

- STANDARD CONNECTION
- - - OPTIONAL CONNECTION
- - - STANDARD CONNECTION ON GAS AND DIESEL MACHINES
- ..... MECHANICAL CONNECTION

**IGNITION**

ENGINE CONNECTOR 1	
A	VSW
B	ALT EXCITE
C	FUEL PUMP -
D	FUEL PUMP +
E	AUX PWM 2
F	START COMMAND
G	MIL (MALFUNCTION)
H	FUEL SELECT (AUX DIG 1)
J	FPP2/IVS
K	FPP1
L	5V RTN 1
M	5V EXT 1
N	CAN 1 +
P	CAN 1 -
R	5V RTN 2
S	5V EXT 2 (FPP2 ONLY)

ENGINE CONNECTOR 2	
A	UNUSED
B	AUX PWM 5 RECIRC
C	AUX PWM 5
D	TACH
E	GROUND
F	AUX PWM 1
G	AUX ANA PU2
H	AUX ANA PU1
J	GOV SELECT 2
K	GOV SELECT 1
L	AUX DIG 2
M	AUX DIG 3
N	VS +
P	VS -
R	AUX ANA PD1
S	12V RELAYED POWER

**INSTRUMENT GAUGE**

A	POWER +
B	LIGHTS
C	GROUND
D	OIL PRESSURE
E	TEMPERATURE
F	N/C

**HEAD/TAIL LIGHTS**

A	RIGHT OUTER HEADLIGHT
B	RIGHT INNER HEADLIGHT
C	LEFT OUTER HEADLIGHT
D	LEFT INNER HEADLIGHT
E	RIGHT TAIL LIGHT
F	LEFT TAIL LIGHT

**HORN**

A	HORN
---	------

**INDICATOR LIGHTS**

A	RECOVERY TANK FULL LIGHT
B	SOLUTION TANK EMPTY LIGHT
C	FIRE IN HOPPER LIGHT
D	CLOGGED FILTER LIGHT
E	OFF AISLE WAND LED
F	SQUEEGEE LED

**OFF AISLE WAND**

A	OFF AISLE WAND RELAY
B	OFF AISLE WAND PUMP
C	SQUEEGEE LIFT/LOWER
D	SQUEEGEE IMPELLER

**SQUEEGEE**

A	SQUEEGEE LIFT/LOWER
B	SQUEEGEE IMPELLER

**VACUUM TIMER**

A	OFF AISLE WAND RELAY
B	OFF AISLE WAND PUMP
C	SQUEEGEE LIFT/LOWER
D	SQUEEGEE IMPELLER

**OPC TIMER**

A	OPC SAFETY RELAY
---	------------------

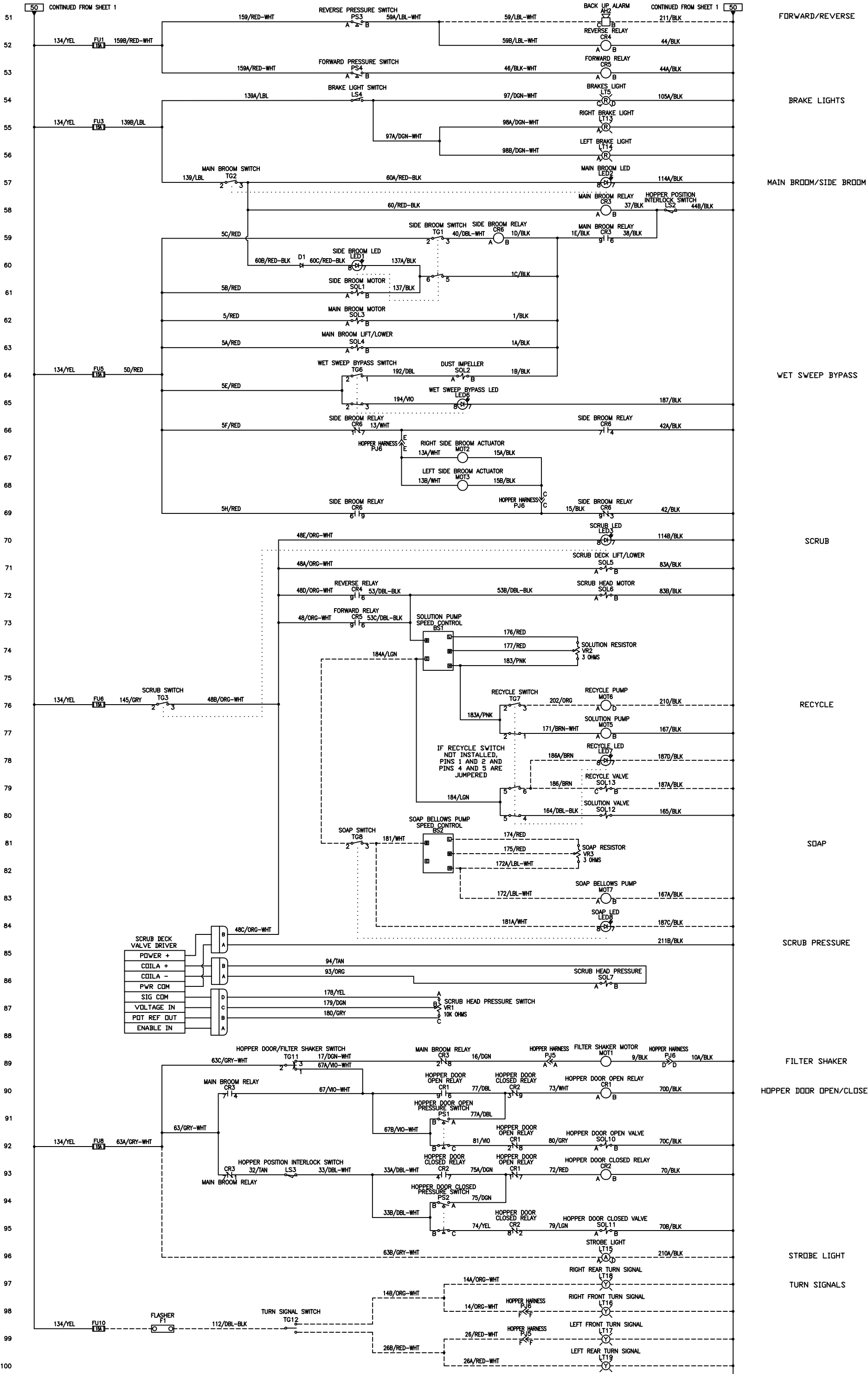

REV	ECN	DATE	DESCRIPTION	BY	175 ANDERSON STREET ABERDEEN, MO 64505 PHONE: (816) 944-2105 FAX: (816) 944-7409	1800/CORE 50 GAS/LP	DATE	PART NUMBER	REVISION	PAGE NUMBER
	10157	2/18/08	RELEASED FOR PRODUCTION	AMD		SCHEMATIC-ELECTRICAL, 1800/CORE 50 GAS/LP	4/14/07	3342952	*	2 OF 2



CONFIDENTIAL  
 THIS DRAWING AND ALL INFORMATION CONTAINED HEREIN ARE THE EXCLUSIVE PROPERTY OF POWERBOSS CORPORATION. NO PART OF THIS DRAWING OR INFORMATION CONTAINED HEREIN IS TO BE REPRODUCED, COPIED, OR TRANSMITTED IN ANY FORM OR BY ANY MEANS, ELECTRONIC OR MECHANICAL, INCLUDING PHOTOCOPYING, RECORDING, OR BY ANY INFORMATION STORAGE AND RETRIEVAL SYSTEM, WITHOUT THE WRITTEN PERMISSION OF POWERBOSS CORPORATION.